

Weigh Module

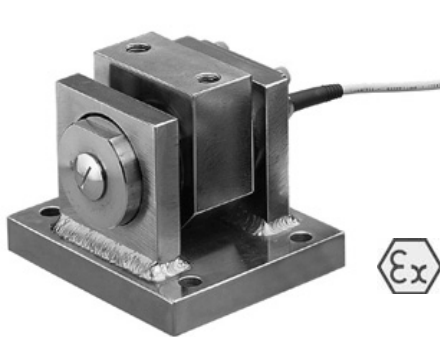

FEATURES

- Suitable for load and level monitoring in storage tanks
- Rugged design
- ATEX approved
- Simple installation

DESCRIPTION

The KOM-1 weigh module has an accuracy, which makes it especially suitable for load and level monitoring in storage tanks.

The sensing element consists of three sections. The two outer sections constitute supports and rest on the built-in block, which is secured to the base. On the middle section, which is the load sensing part, there is a yoke to which the leg of the tank is secured. The sensor is efficiently locked so that it cannot twist in the built-in block.

APPLICATIONS

- Process weighing
- Level monitoring

OUTLINE DIMENSIONS

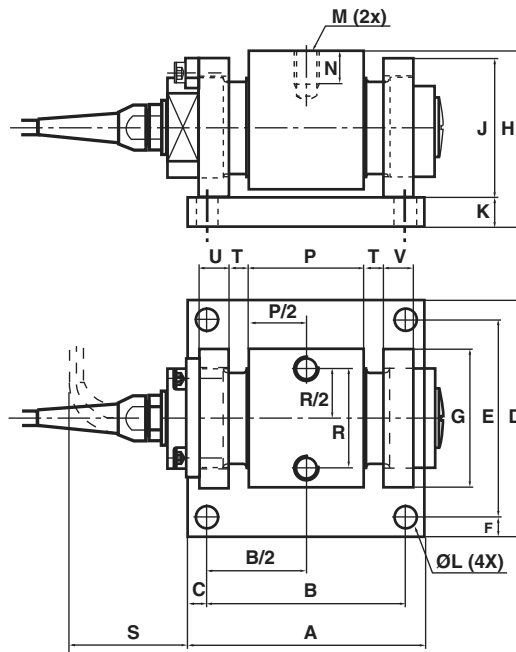

RANGE kN	A	B	C	D	E	F	G	H±1	J	K ⁰ ₋₁	ØL
10-20-50	120	100	10	120	100	10	70	89	70	15	11
100	120	100	10	120	100	10	70	89	70	15	11
200	140	90	25	170	140	15	100	135	100	24	14

RANGE kN	M	N	P	R	S	T	U ⁰ ₋₁	V ⁰ ₋₁
10-20-50	M12	18	33	50	47	10	15	15
100	M12	18	48	50	60	10	20	20
200	M16	28	48	70	50	10	30	20

SPECIFICATIONS

Rated load (R.L.)		10, 20, 50, 100, 200	kN
Typical combined error (terminal)		0.25	% of R.O.
Repeatability		0.25	% of R.O.
Overload	safe*	100	% of R.L.
	ultimate*	200	% of R.L.
Input voltage	recommended	10	V DC or AC
	maximum	18	V DC or AC
Input resistance		350±5	ohm
Output resistance		350±5	ohm
Rated output (R.O.)		1	mV/V
Zero balance		±5	% of R.O.
Tolerance of shunt calibration values		±1	% of value**
Temperature range		-40 to +80 (+100)***	°C
Temperature effect	on output	±0.04	% of output/°C
	on zero balance	±0.04	% of R.O./°C
Insulation resistance at 200V DC		>4	Gohm
Material: Load Cell		Stainless steel	
	Built in block	Yellow chromate steel	
Electrical connection		5m shielded four conductor cable	10, 20, 50kN
		10m shielded four conductor cable	100, 200kN
Degree of protection		IP 67	
* Referring to recommended loading case			
** See calibration sheet of the load cell		ATEX certified versions for load cell KOSD-40 in weigh module KOM-1 for use in explosive atmospheres are available: II 1GD. EEx ia IIC T4 T _{amb} = 60°C	
*** -40 to +100°C on demand			

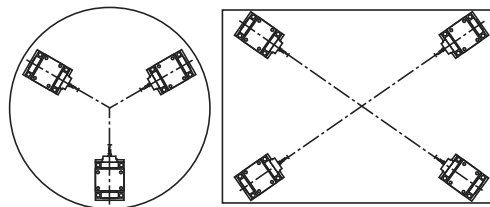
INSTALLATION EXAMPLES

Disclaimer

All product specifications and data are subject to change without notice.

Vishay Precision Group, Inc., its affiliates, agents, and employees, and all persons acting on its or their behalf (collectively, "Vishay Precision Group"), disclaim any and all liability for any errors, inaccuracies or incompleteness contained herein or in any other disclosure relating to any product.

Vishay Precision Group disclaims any and all liability arising out of the use or application of any product described herein or of any information provided herein to the maximum extent permitted by law. The product specifications do not expand or otherwise modify Vishay Precision Group's terms and conditions of purchase, including but not limited to the warranty expressed therein, which apply to these products.

No license, express or implied, by estoppel or otherwise, to any intellectual property rights is granted by this document or by any conduct of Vishay Precision Group.

The products shown herein are not designed for use in medical, life-saving, or life-sustaining applications unless otherwise expressly indicated. Customers using or selling Vishay Precision Group products not expressly indicated for use in such applications do so entirely at their own risk and agree to fully indemnify Vishay Precision Group for any damages arising or resulting from such use or sale. Please contact authorized Vishay Precision Group personnel to obtain written terms and conditions regarding products designed for such applications.

Product names and markings noted herein may be trademarks of their respective owners.